

M-2 Menu Flow Chart

Mode 0

Mode 0 is used to configure start/stop, TFD, FVS and 4-20mA output

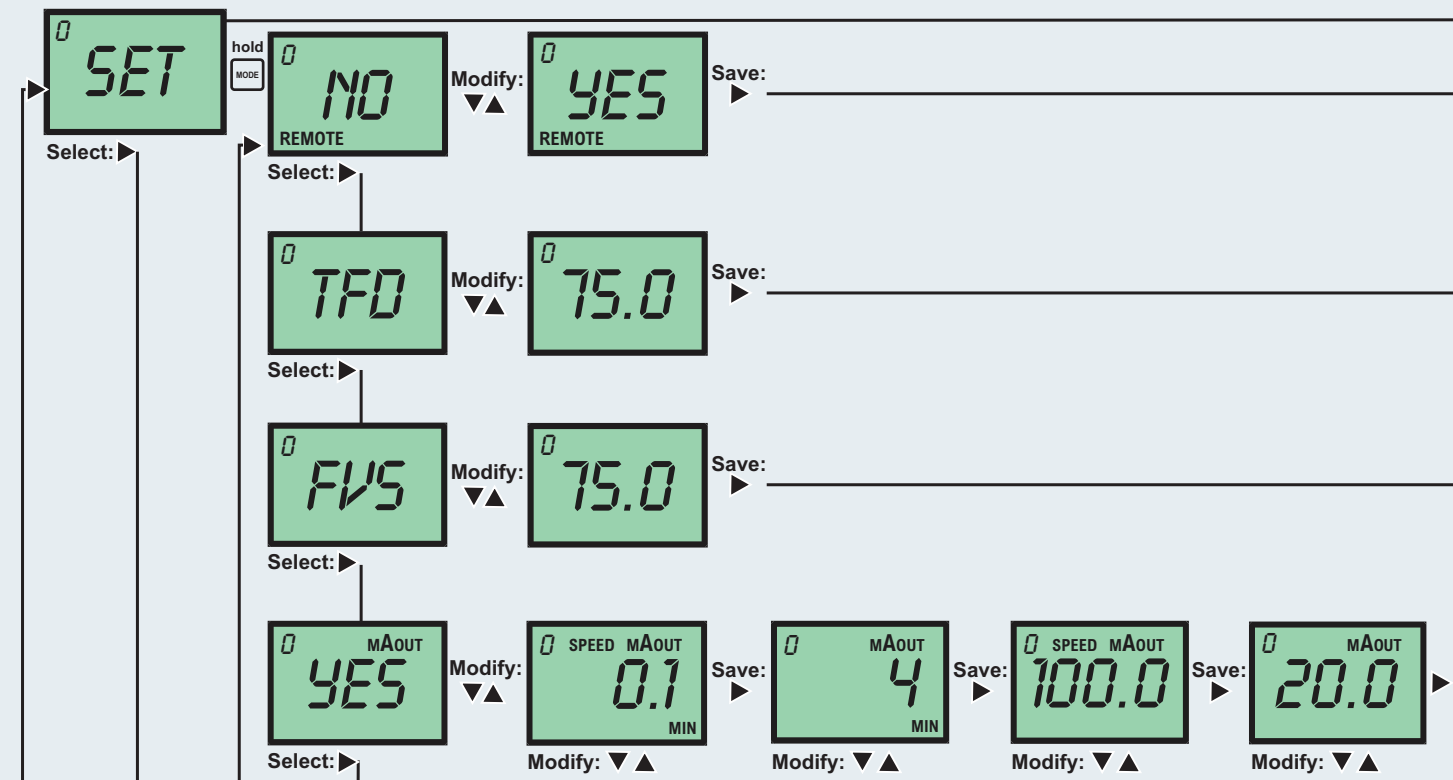

Modes 1 thru 4

Modes 1-4 are local and remote operating modes

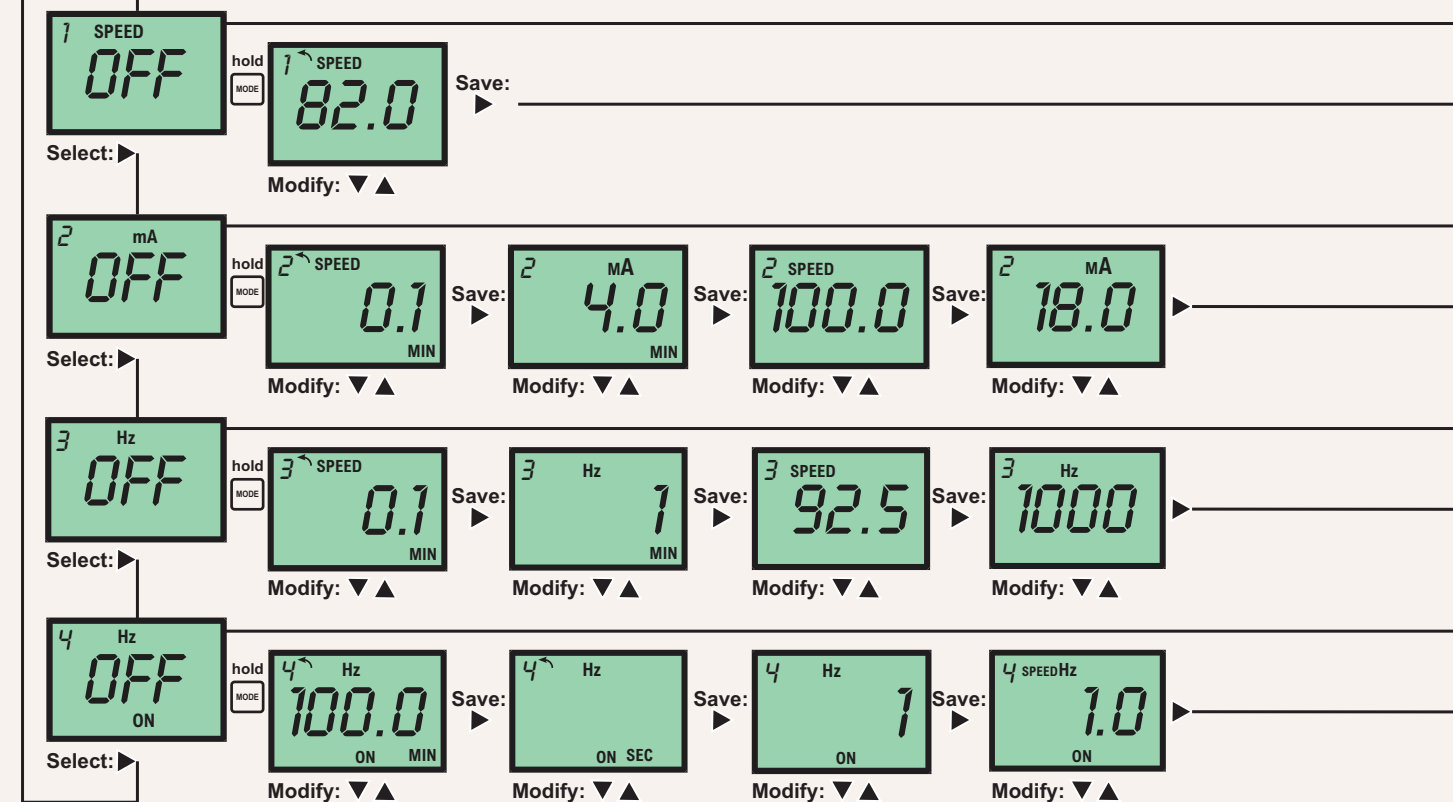

How to Operate Flex-Pro - Control Pad

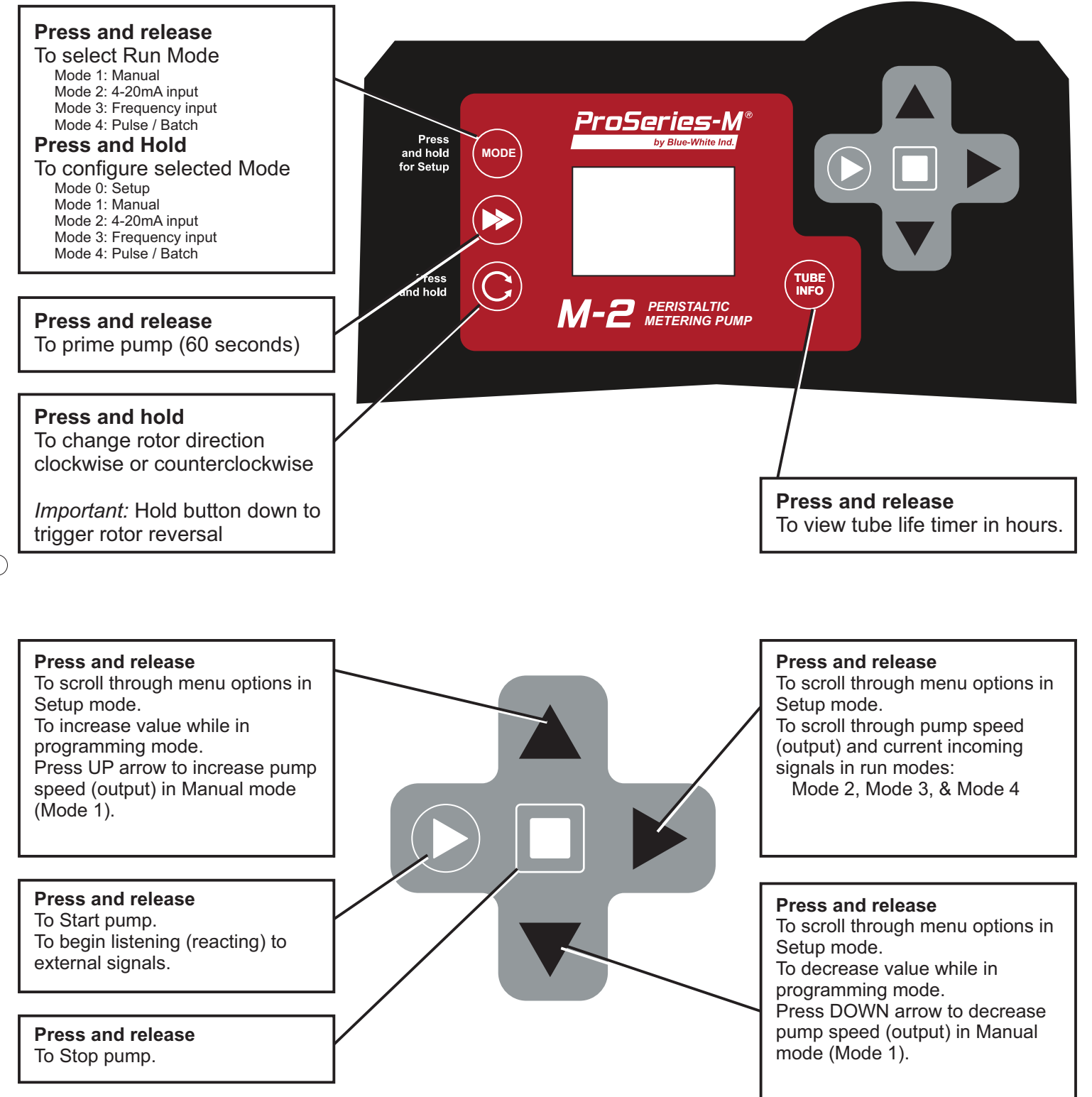

Wiring Terminals and I/O Schematics

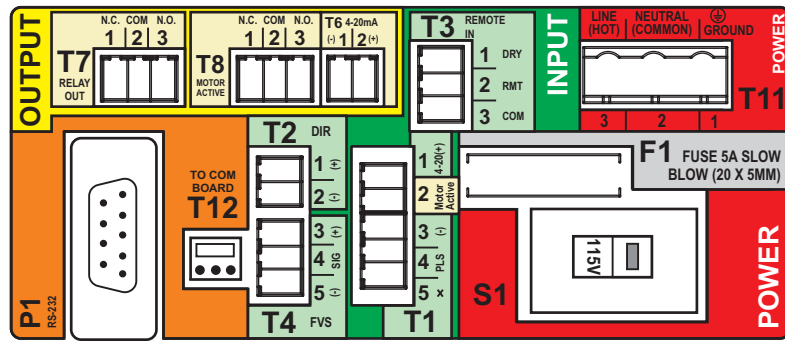

WARNING Risk of electric shock - All wiring must be insulated and rated 300V minimum.



Terminals T1 Thru T8 Plug type 16 - 24 AWG
Power Input Terminal T11 Plug type 14 - 30 AWG

Shielded cables should be used on all input signal wires.

FUNCTION	TERM	PIN #	RATING	ELECTRICAL SP.	BLOCK DIAGRAM
INPUT: 4-20 mA	T1	1	(+) POSITIVE	120 OHM IMPEDANCE, NON POWERED LOOP	Single or dual pump (series) input. Loop voltage must not exceed 24 Volts. ACTIVE 4-20mA TRANSMITTER SOURCE
	T1	3	(-) NEGATIVE		
INPUT: FREQUENCY, AC SINE WAVE, TTL, CMOS	T1	3	(-) NEGATIVE	0-1000 HZ MAX.	FREQUENCY TRANSMITTER SOURCE
	T1	4	(+) POSITIVE		
INPUT: FVS SYSTEM (FLOW VERIFICATION SENSOR) FV SENSOR ONLY	T4	3	(+) POSITIVE	SIGNAL	BLUE-WHITE FVS SENSOR
	T4	4	SIGNAL		
	T4	5	(-) NEGATIVE		
INPUT: FVS SYSTEM (FLOW VERIFICATION SENSOR) FS or FP MICRO-FLO FLOW METER ONLY	T4	4	SIGNAL	SIGNAL	BLUE-WHITE MICRO-FLO FLOWMETER PULSE OUTPUT
	T4	5	(-) NEGATIVE		
INPUT: REMOTE START / STOP (DRY CONTACT C.)	T3	1	(+) POSITIVE	NO VOLTAGE	NOTE: USE ONLY DRY CONTACT FOR REMOTE S/S WHEN USING 4-20mA INPUT
	T3	2	(-) NEGATIVE		
INPUT: REMOTE START / STOP (WET CONTACT C.)	T3	2	(+) POSITIVE	6 TO 30 VOLT DC 1 AMP MAX.	EXTERNAL DEVICE 6 TO 30V DC
	T3	3	(-) NEGATIVE		
OUTPUT: 4-20 mA	T6	2	(+) POSITIVE	120 OHM RESISTANCE ACTIVE LOOP	4-20mA RECEIVER 600 OHM LOAD MAX.
	T6	1	(-) NEGATIVE		
OUTPUT: RELAY, 3 AMP	T7	1	NORM. CLOSED	Form C 3 AMP MAX AT 250 VAC, 3 AMP MAX AT 30 VOLT DC	SWITCH LOAD 3 AMP MAX @ 250V AC, 3 AMP MAX @ 30V DC
	T7	2	COMMON		
	T7	3	NORM. OPEN		
OUTPUT: OPEN COLLECTOR MOTOR ACTIVE	T1	2	SIGNAL	5 TO 24 VDC	CLOSED WHILE MOTOR IS ENERGIZED
	T1	3	COMMON		
OUTPUT: MOTOR ACTIVE (CONTACT CLOSURE)	T8	1	NORM. CLOSED	Form C 1 AMP MAX AT 125 VAC, 0.8 AMP MAX AT 30 VOLT DC	SWITCH LOAD 1 AMP MAX @ 125V AC, 0.8 AMP MAX @ 30V DC
	T8	2	COMMON		
	T8	3	NORM. OPEN		
INPUT: POWER	T11	1	GROUND	115V OR 230V AC MANUAL SWITCH 50 / 60 HZ 100W	AC VOLTAGE
	T11	2	NEUTRAL		
	T11	3	LINE (HOT)		
FUSE	F1	N/A	5 AMP	5A SLOW BLOW (20 X 5MM)	SWITCH FROM 115V TO 230V

ProSeries-M
by Blue-White Ind.

5300 Business Drive, Huntington Beach, CA 92649 USA
Phone: 714-893-8529 FAX: 714-894-9492

E mail: sales@blue-white.com or techsupport@blue-white.com URL: www.ProSeries-M.com

85000-118 Rev 5. 10142019



ProSeries-M® M-2 Peristaltic Metering Pump
QUICK START GUIDE

Mounting Location

- ✓ Choose an area located near the chemical supply tank, chemical injection point, and electrical supply. Install the pump where it can be easily serviced.
- ✓ Mounting brackets are included. Mount the pump to a secure surface using the enclosed mounting hardware.
- ✓ Mount the pump close to the injection point. Keep the inlet (suction) and outlet (discharge) pipe or tubing as short as possible. Longer discharge tubing increases back pressure at pump head.
- ✓ Keep the suction lift height as low as possible. Increased suction lift heights can decrease the pump's efficiency.
- ✓ A back flow prevention check valve is recommended at the injection point to prevent system fluid from flowing back through the pump during tube replacement or if the tube should rupture. **The check valve internals must be kept clean.** Any build up in the valve will increase the pressure at the pump reducing the life of the pump tube. Back flow check valves are available from the factory.
- ✓ The Flex-Pro does not require back pressure. Pressure regulator valves should **NOT** be used as back-flow prevention valves unless adjusted to the minimum possible opening pressure. **Any additional pressure at the pump will reduce the life of the pump tube.**
- ✓ A pressure relief valve is recommended at the discharge of the pump to prevent excessive pressure resulting in premature wear and damage to the pump tube in the event the discharge line becomes blocked.

Maximum working pressure (excluding pump tubes):

125 psig (8.6 bar)
Note: see individual pump tube assembly maximum pressure ratings.

Maximum Fluid temperature (excluding pump tubes):

3/8" OD x 1/4" ID tubing connections: 130° F (54° C)
M/NPT connections: 185° F (85° C)
Note: see individual pump tube assembly maximum temperature ratings.

Ambient Operating Temperature

14°F to 115°F (-10°C to 46°C)

Ambient Storage Temperature

-40°F to 158°F (-40°C to 70°C)

Operating Voltage:

115VAC/60Hz, 1ph (1.5 Amp Maximum)
230VAC/60Hz, 1ph (0.7 Amp Maximum)
220VAC/50Hz, 1ph (1.0 Amp Maximum)
240VAC/50Hz, 1ph (1.0 Amp Maximum)

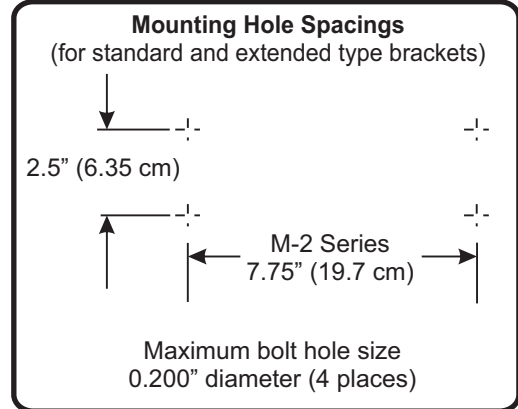

- WARNING** Risk of electric shock – cord connected models are supplied with a grounding conductor and grounding-type attachment plug. To reduce risk of electric shock, be certain that it is connected only to a properly grounded, grounding-type receptacle.
- WARNING** Electrical connections and grounding (earthing) must conform to local wiring codes. Be certain that a grounding conductor is connected to terminal T11-1 located in the wiring compartment.
- WARNING** Risk of electric shock - Disconnect electricity before removing the wiring compartment cover.
- CAUTION** Risk of chemical overdose. Be certain pump does not overdose chemical during backwash and periods of no flow in circulation system.
- CAUTION** Always wear protective clothing, face shield, safety glasses and gloves when working on or near your metering pump. Additional precautions should be taken depending on solution being pumped. Refer to MSDS precautions from your solution supplier.
- CAUTION** All diagrams are strictly for guideline purposes only. Always consult an expert before installing metering pump on specialized systems. Metering pump should be serviced by qualified persons only.